

Business as Unusual

Sophia Fasano, Ashley Ferraro, Daniel Knorr, Ethan Staten

12/10/2020

Capstone Design ECE 4440 / ECE 4991

Signatures

Daniel Knorr

Sophia Fasano

Ethan Staten

Ashley Ferraro

Statement of work:

Daniel Knorr

My contributions this semester started with the designing of the block diagrams for the system as a whole and selecting the components and modules that we would use. The decision on the motor driver module was determined primarily by the motors available from the previous project we were basing the frame off of.

In the PCBs, I designed the power system using the 9 V battery and the voltage regulator for supplying voltage to the inertial measurement units, the bluetooth modules, and the driver chips. I worked on the power system for the first board send out and it did not need reworking after our first round of testing. I also designed the connections for the bluetooth modules to the microcontroller on both PCBs. This was a simple section of the design that needed to be reworked and I made adjustments to the routing of the Rx and Tx lines for the second board sendout. I originally designed circuitry for natively supporting the DRV8825 driver chip on our PCB, however with time constraints and difficulty matching the layout requirements specified in the device data sheet, I made the design switch to a modular version of the motor driver.

For the headset, I spent the beginning of the semester designing the supporting circuitry for the inertial measurement unit (IMU). Due to the nature of the IMU chips, I did not anticipate being able to solder the chips with their 24 pins properly onto the PCB. To mitigate this, I was the main liaison for getting our parts soldered by a third party. Because I was the main liaison for having the IMUs solder, I elected to also have the rest of the analog circuitry soldered by the third party as well to save time. Since I was in charge of having the boards ready for send out and soldering, I was responsible for part orders, layout documentation, soldering instructions, and part inventories. As an extension of these duties, I was responsible for communicating with the third party for PCB soldering as well as drop off and retrieval of materials.

When it came time for testing, I worked with Sophia to validate the power supply on the headset PCB, test bluetooth connectivity, and test the transmission of IMU data. I was responsible for providing the code for allowing the microcontroller to read the IMU data via I2C protocol and then sending that data over bluetooth. Due to a design issue with reading bluetooth data from a slave bluetooth module, I worked to connect to the bluetooth module via a terminal to inspect whether the data was representative of the motion of the device. Finally, when troubles arose with the integrated IMUs on the headset PCB, I prepared an emergency modular solution so that we would still have IMU data to test with.

Ethan Staten

My initial contribution to this capstone project was researching sensors capabilities for the purpose of utilization and integration into our project. The team decided early on that we would most likely use IMUs as our main sensor. However, I wanted to do my due diligence in making sure that we picked an IMU robust enough to handle all the tasks we sent its way. After some searching and discussions with the team, we eventually settled on the MPU 6050 series of IMUs. Through examination of online reviews and datasheet specifications, I believe that the chosen IMU will serve our team well in the weeks to come.

Switching gears somewhat, I decided that I wanted to approach the capstone design from the back end of the timeline and start creating some initial test plans. As shown in the Gantt chart, testing will be one of the last things that our team will do. However, I believe that taking time to initially form some test plans will save us exponentially more time later on in the design process. My initial set of test plans have focused less on explicit numerical results and more so on general working conditions. I expect to update these test plans as we progress through the design process of our capstone. The initial set of test plans cover the MSP430, the HC05 Bluetooth module, the MPU 6050 IMUs, and the DRV8825 Stepper Motor, shown by Figures 6, 7, 8, and 9 respectively, shown in the Appendix. After constructing the test plans, I assisted with the development, implementation, and testing of the motor controller code.

Sophia Fasano

At first, I focused on the physical hardware components of the automated ring light. First, I designed the ring light's system of movement, taking into consideration what parts were available to us at the NI Lab. I then conceptualized the best possible stand considering weight, cost, and the tools I had available. I determined to make a stand out of CPVC that had a wide base with supporting struts in the front that allowed for balance, while allowing the device to fit behind a laptop without blocking the user's access to their desk.

Next, I then helped with the development of the code for testing the bluetooth and IMU hardware, along with the actual testing of the hardware. Finally I worked on the software to drive the motors. Next, I designed a finite state machine for the movement design. I then made it so the light would respond to commands, along with stopping at the end switches.

Ashley Ferraro

I contributed to the project by implementing the HC-05 bluetooth module that was needed for the schematic of the system. I also encouraged team collaboration by creating and maintaining a Github for our team that allowed the code shared in the project to be accessible. I produced a high level outline of how the movement algorithm should address the positioning of the ring light based on the movement of the user's head. Thereafter based on this abstract outline I created and tested the software necessary for accurate motor movement based on the data relayed from the IMU. This included the operation of the two motors, both the webcam and lateral movement motors. I also worked on debugging and configuring the operation for the stepper motor drivers. This included generating two waveforms from the MSP430 to control the amount of steps both motors took along with making the movement consistent among multiple operations.

I also assisted with the design and component calculations for both PCBs. This included the Bluetooth transceiver PCB and the Bluetooth receiver PCB that was integrated with the MSP430 as well as the motor. During each iteration of the PCB I helped in additional debugging in order to isolate problems that were plaguing our project. This included improper connections as well as spontaneous open circuits from high current draw, both of which damaged the first iterations in our project. While these issues were largely resolved both bugs posed a challenge to isolate and fix.

Table of Contents

Capstone Design ECE 4440 / ECE4991	1
Signatures	1
Statement of work:	2
Table of Contents	4
Table of Figures	5
Abstract	6
Background	6
Design Constraints	7
External Standards	7
Tools Employed	7
Ethical, Social, and Economic Concerns	8
Intellectual Property Issues	9
Detailed Technical Description of Project	10
Project Timeline	20
Test Plan	22
Final Results	26
Costs	28
Future Work	29
References	30
Appendix	31

Table of Figures

Figure 1: Patent Figure of Actuated Light Fixture	9
Figure 2: Patent Figure of Wearable Gaze Tracking Device	10
Figure 3: Headset Block Diagram	11
Figure 4: Implementation of an MPU-6050 used in the Sensor Array	12
Figure 5: Voltage Regulator Implementation	13
Figure 6: Headset Subsystem Schematic	13
Figure 7: Board Layout for the Headset Subsystem	14
Figure 8: Block Diagram of the Motor Controller Subsystem	15
Figure 9: DRV8825 Motor Driver Chip Implementation	16
Figure 10: Motor Controller Subsystem Schematic	17
Figure 11: Motor Control PCB	18
Figure 12: Frame Apparatus	19
Figure 13: Gantt Chart from Project Proposal	19
Figure 14: Final Gantt Chart	20
Figure 15: MSP430 Test Plan	21
Figure 16: HC05 Bluetooth Test Plan	22
Figure 17: IMU Test Plan	23
Figure 18: DRV8825 Stepper Motor Test Plan	24
Figure 19: Power Verification Measurement	25
Figure 20: Bluetooth Module Verification	26
Figure 21: IMU Data Over Bluetooth	26
Figure 22: Finite State Machine	27

Abstract

The Automated Ring Light is a device for providing direct illumination to the user's face as they move about their workstation. Mounted on the primary monitor, it will track the user's movements via a sensor on a headset and move left and right and rotate as needed to keep the ring light directly focused on the user from any angle they work at. In the age of video conferencing and the prevalence of appearance based judgements in the workplace, this device aims to present the user at their best to co-workers, clients, and managers.

Background

In the Summer of 2019, one member of the Business as Unusual team found himself working on a project that involved the headshots of full time engineers at his company. He went ahead and used the pictures stored in the human resources system. His manager, Jane, approached him about the headshot used for one of her coworkers, Alice. Jane let him know that the picture he used for Alice looked really bad. Jane informed him that female engineers who did not present themselves in full makeup with good lighting were seen as less capable and would get fewer contracts and advancement opportunities. Jane decided to ask her friend Alice for a more flattering headshot which eventually was used in the project. With the advent of mass video conferencing, employees' faces are on display in close up formats more than ever before. In a study published by the *Journal of Applied Psychology*, it was found that "Managers judged that highly attractive candidates were more suitable for hire than marginally attractive candidates [1]." It remains challenging to address internal biases, however the Automated Ring Light aims to prevent the user from missing out on any opportunities on the basis of their appearance.

The standard ring light as is commonly used by vloggers and internet influencers is not a new device. There have been slight modifications to the general idea in recent years, such as a tripod attachment filed with the United States Patent Office in 2019 [2], but the introduction of motion responsive lighting for consumer use is new. A similar product is found in the home security space. A patent for a motion tracking outdoor floodlight was filed in 2010 by Nightwatcher Electronics Pty Ltd. This device is similar in that it directs the light toward the source of motion, however it is intended for broad rather than targeted illumination [3]. The Nightwatcher device sensor identifies various sectors and directs the light to motion filled sectors rather than tracking the specific angles of a close up target's face.

The goal of precisely directed illumination of a nearfield target distinguishes the Automated Ring Light from other products in the space. The sensors used in this project are specifically designed to provide facial angle and positional data on the centimeter scale rather than the meter scale seen in outdoor applications of similar technology. Additionally, the Automated Ring Light is intended to mount on or around a monitor rather than sit behind the user's screen as is the case with the tripod mounted solution.

This project covers a number of areas that will require skills developed in previous courses. The leadscrew for left and right translation and stepper motor for angle adjustment will both communicate with the microcontroller via UART protocol to accommodate a quick response to small movements. This was a topic covered in a number of embedded systems projects in ECE 3430. The IMU on the headset will be powered by an isolated battery similar to the electrode isolation designed in ECE 3750 as part of the EKG. The use of bluetooth and its standards utilizes

lessons from ECE 4501. On a more holistic level, the design of the product in the various stages of execution will draw from knowledge gained in SYS 3048 and SYS 3501 which included projects on signal processing and prototyping.

Constraints

Design Constraints

Our first constraint was time constraints, such as time for shipping and board send outs. This limited our ability to experiment with different PCB layouts in order to optimize performance and size. As a result, certain components had to be used as modules instead of chips in order to implement different portions. We often had to spend many for expedited shipping in order to ensure we had time to properly test hardware. One benefit, was the parts often come in multiples, allowing for multiple configurations to be tested.

Economic and Cost Constraints

The first and most immediate cost constraint is the Capstone budget of \$500. This limited the amount of prototypes we could produce due to the cost of materials. Another constraint was the recycling of a previous capstone project which was reconfigured for the frame apparatus. This meant we could not produce multiple prototypes concurrently or risk breakage for this unique section of the project.

Some of the components used in this project came in modular form, such as the DRV8825 driver chip module. These helped in allowing for faster debugging but presented an economic obstacle as the vendors had minimum order requirements which increased the cost of parts. Another cost constraint was that prior to testing there was no guarantee which sections would work and which parts of the PCBs would need reconfiguring. Serious malfunctions could have meant needing to reorder parts. For this reason, the costs had to be kept under \$500 by a safe cushion so that there would be money left over in the event of serious failures during testing.

External Standards

When considering the safety and compatibility of the Automated Ring Light there are a few factors to consider. First, electrical components shall meet power requirements throughout the design, while also adhering to physical spacing and enclosure requirements. The device also will be designed to meet communication standards. For our current prototyping purposes, we will be evaluating and adhering to both 802.11ac wireless standards [3] and Bluetooth standards [4]. For all PCB designs, operational standards will be upheld for all software and electronic hardware devices, including design standards for header board/PCB designs. Structural limitations for physical prototype and structure will be observed and upheld.

Tools Employed

For hardware, we utilized both Multisim and Ultiboard in order to layout and design the PCBs for both the headset and ring light component. This required the improvement in our design and debugging skills, since we did not have a layout to reference beyond the data sheets.

For software, we utilized primarily C in Code Composer to run our code. While doing initial hardware testing, we utilized Energia in order to utilize their robust toolkits in order to more quickly test the hardware.

Ethical, Social, and Economic Concerns

Environmental Impact

One environmental concern of this project is the use of disposable batteries as a power source. The disposal of batteries can be potentially damaging to the environment. If improperly disposed of, they can contribute to both air and water pollution. [5] They also contain toxic and potentially harmful materials such as cadmium, mercury, lead, or lithium. [5] LEDs also cause possible environmental damage if improperly disposed off. [6]

Sustainability

In regards to a short-term, small scale level of our project, some parts of our physical design can be considered sustainable. A sizable portion of the frame apparatus was recycled from a previous capstone project, along with some wires, connectors, and testing components. However, if the project was scaled up to a long-term, large scale level of production, our team struggles to see how our project can be sustainable. The most likely room for improvement concerning sustainability would be proper disposal and/or recycling of batteries and LEDs.

Health and Safety

Some parts of the device that are identifiable health and safety concerns include the brightness of the mounted LEDs, interaction with leadscrew's lubricant, and the uncovered movement of the nut lead. The brightness of the LEDs will cause eye strain and even potentially blindness if a person sustains eye contact for long periods of time. To reduce the risk of this a maximum brightness will be set by limiting the maximum current applied to the LED. Furthermore, an accessible off switch will be made available to the user as well.

Manufacturability

We are optimistic that this device can be scaled up for manufacturing. The design is modular and can be separated into three parts. This includes the leadscrew with stepper motor, the nut lead, and the headset. Similar to how parts from a 3D printer are assembled and shipped the ring light will be similar. Each of these units can be manufactured separate from one another and then placed together in packaging. The user can then follow the instructions to assemble these separate parts along with connecting certain wires together. This is desirable as attaching the ring light's nut lead to the leadscrew will require specialized machinery, and will as a result inflate the cost of the product.

Ethical Issues

One projected issue with the Automated Ring Light is that it does not attempt to solve the issue of appearance bias. Instead it plays into appearance by instead aiming to improve the presentation of the user. By doing so, the Automated Ring Light perpetuates appearance bias. In a way rather than addressing the cultural problem of people being unfairly judged on presentation,

we are creating a product that improves the user’s presentation due to the cultural issue they face. This leads to more people conforming to bias expectations, which further normalizes the bias. [7]

Furthermore, another projected issue is the anticipated high cost of the device. This could potentially bring concerns about possible class discrimination. Considering the intersectionality of appearance bias and class bias, it is pertinent to also consider the relationship between those who are perceived as “more attractive” and higher average salaries. [8] The combination of a high price along with the Automated Ring Light contributing to potential appearance bias, while helping minimize the effects of appearance bias for an individual, could result in further expanding and enforcing the effects of appearance bias in the workplace as a whole.

Intellectual Property Issues

A patent application that was relevant to our functionality of the moving light source is US20130155672A1 [9] which presents a moving light source actuated by multiple motors on a rail. The movement of these motors was to be determined by one to two sensors or a controller. The figure included with this patent application is shown in Figure 1.

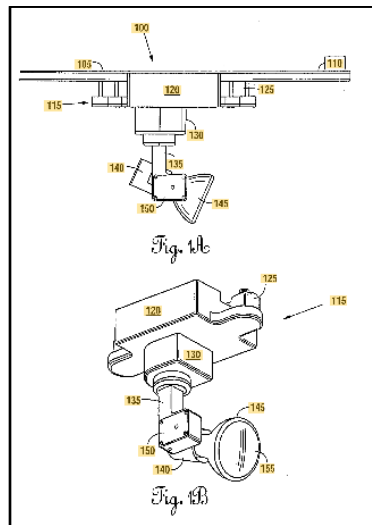

Figure 1: Patent Figure of Actuated Light Fixture

This patent application was abandoned, however any application regardless of status as patents are public prior art. This means this failed application can be used in an office action to strike any claims from an incoming application. As evident in the claims shown in this application, we are unable to patent the means for our ring light to move and receive data as this application presents in claim 3 an identical mechanism to ours. It describes a track-light module that uses location information to actuate motors to illuminate a target object. It is likely that under United States patent code any attempt to submit an application of our invention will receive a U.S.C 102 patent rejection in which the proposed application is considered not novel or is anticipated.

It is possible to refine the claims in our hypothetical patent application in which we can patent a subsection or revised perspective of our design in order to receive some intellectual property protection. A possible interpretation of our design can be to reframe it as a device that uses the data relayed by an item or paraphernalia located on the head of the user to influence

devices within the vicinity of the user to accommodate their head movements. However, this redefinition would also be rejected as KR20160106629A [10] exists with claims identical to this description.

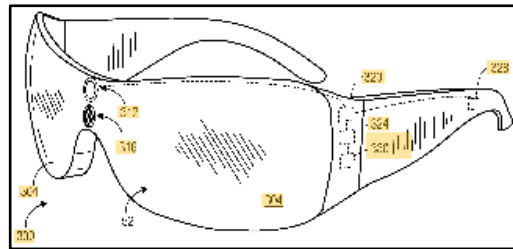

Figure 2: Patent Figure of Wearable Gaze Tracking Device

This patent presents in claim 1 a wearable device mounted on the head that uses the computing device embedded in it to generate data relative to the position of the device itself. It then generates a line of sight from the head pose data. This data can then be exchanged to a target where the positioning data can be corrected or used to update a local display in the area. This proposed redefinition of our device will therefore also receive a U.S.C 102 patent rejection since the means to generate and relay data is identical to this patent.

Finally, another patent that may also invalidate our patent application is shown in US10788673B2. This patent does not possess any figures to accompany it, however the claims and description it has mimics the utility of our device as well. In claim 1 it similarly describes a head mounted device that uses the position data generated from the head's orientation and location to influence devices in its vicinity. Therefore this prior art may also be used in an U.S.C 102 patent rejection.

Based on the prior art as outlined here the patentability of our project is therefore unlikely to be accepted. All of these examples of prior art, and more, can be used in an office action that will result in all claims we provide being stricken. It anticipated that any patent application of the device in its present form will result in either the application being rejected or abandoned. While the utility of the device is novel, its ability to be protected as intellectual property is unfounded. In the future it could be possible to revise parts of the device such that subsections of it are novel and patentable. This can include a prediction algorithm, multiple sensors to provide redundancy, and multiple lights that are capable of generating unique lighting conditions. There is an identifiable route to patentability and if the development of this device were to continue it would likely pursue it.

Detailed Technical Description of Project

This section will describe two design approaches for the automated ring light. The first approach that will be covered is the less modular of the two and features custom implementations of some of the devices used in the design. The second approach is more modular in nature and can be more easily assembled without custom printed circuit boards. A combination of these two approaches were used in order to present a minimum viable product as proof of concept for the automated ring light. There are two main subsystems of the automated ring light. There is the

headset subsystem which detects and transmits motion data and there is the motor control subsystem which uses the motion data to determine how to drive the motors. The motors associated with this subsystem are mounted on the frame apparatus. One motor drives translational motion of the device and the second motor drives the rotational motion of the mounted ring light.

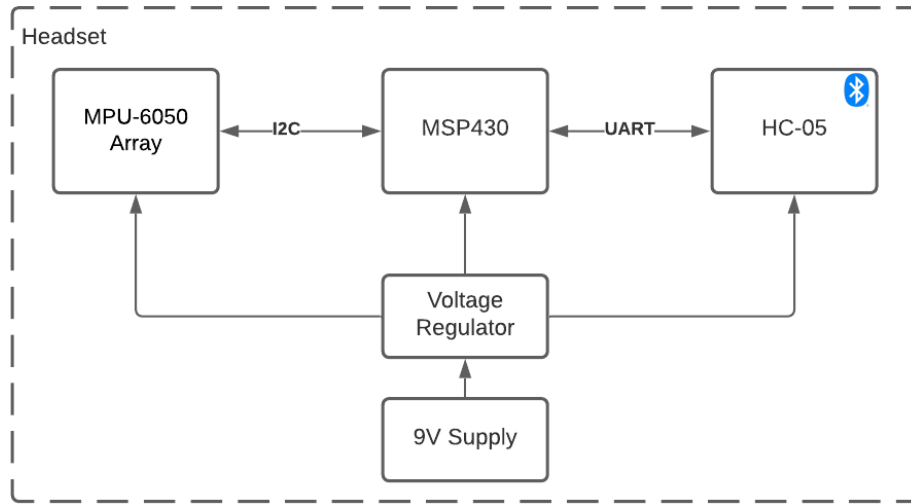

Figure 3: Headset Block Diagram

Figure 3 shows a high level block diagram of the headset subsystem. The MPU-6050 Array consists of two MPU-6050 [11] inertial measurement units which communicate over the I2C protocol with the MSP430. The microcontroller used in this project is the MSP430-E2GET [12]. The microcontroller sends the collected data to the HC-05 [13] bluetooth module over software UART. These components are all supplied with 3.3 V provided by a voltage regulator that is receiving a 9 V battery.

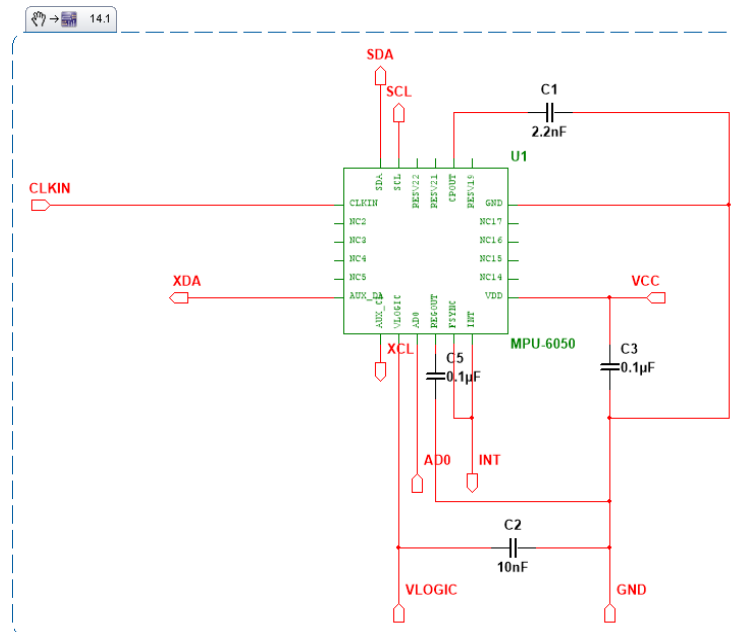

Figure 4: Implementation of an MPU-6050 used in the sensor array

The MPU-6050 array consists of two inertial measurement units (IMU) connected to the I2C bus. In this implementation, the left sensor is addressed as '0' and the right sensor is addressed as '1' on the I2C bus. Figure 4 shows the implementation of one of the IMUs as it is used on the headset PCB. Included are connections for the I2C bus, addressing, power, ground, and bypass capacitors for this active component. The final subsystem schematic in Figure 3 shows the two IMUs connected in parallel on the I2C bus. The MSP430 is connected to the bluetooth module over software UART and as this module is a prefabricated section of this project, it's implementation is not discussed here and this component can be further investigated by inspecting the referenced data sheet.

As both IMUs, the MSP430, and the HC-05 bluetooth module operate using a 3.3 volt VCC connection, a battery and voltage regulator component was needed to provide a reliable and safe operating voltage to these components. Figure 5 shows the implementation of the voltage regulator component that is used for both the headset and the motor controller subsystem. The LMS8117AMP-3.3/NOPB [14] voltage regulator was selected as it could deliver an output in the acceptable operating range for the other components in this subsystem from input of a common 9 V battery.

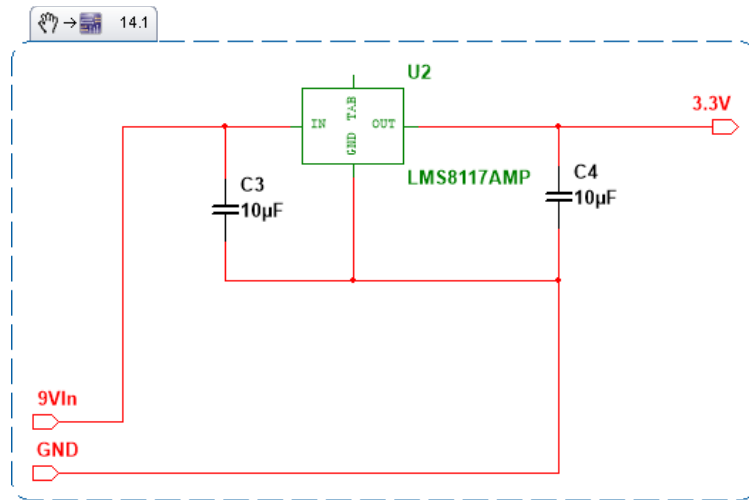

Figure 5: Voltage Regulator implementation

Using the previously described voltage regulator and IMU circuitry as hierarchical blocks, the headset subsystem as a whole can be fully described in Figure 6. The test points that appear on the final PCB are not included in this schematic for clarity. In future implementations of this project, test points can be added as designers see fit and there are suggestions included in the appendix that this team found useful to have included.

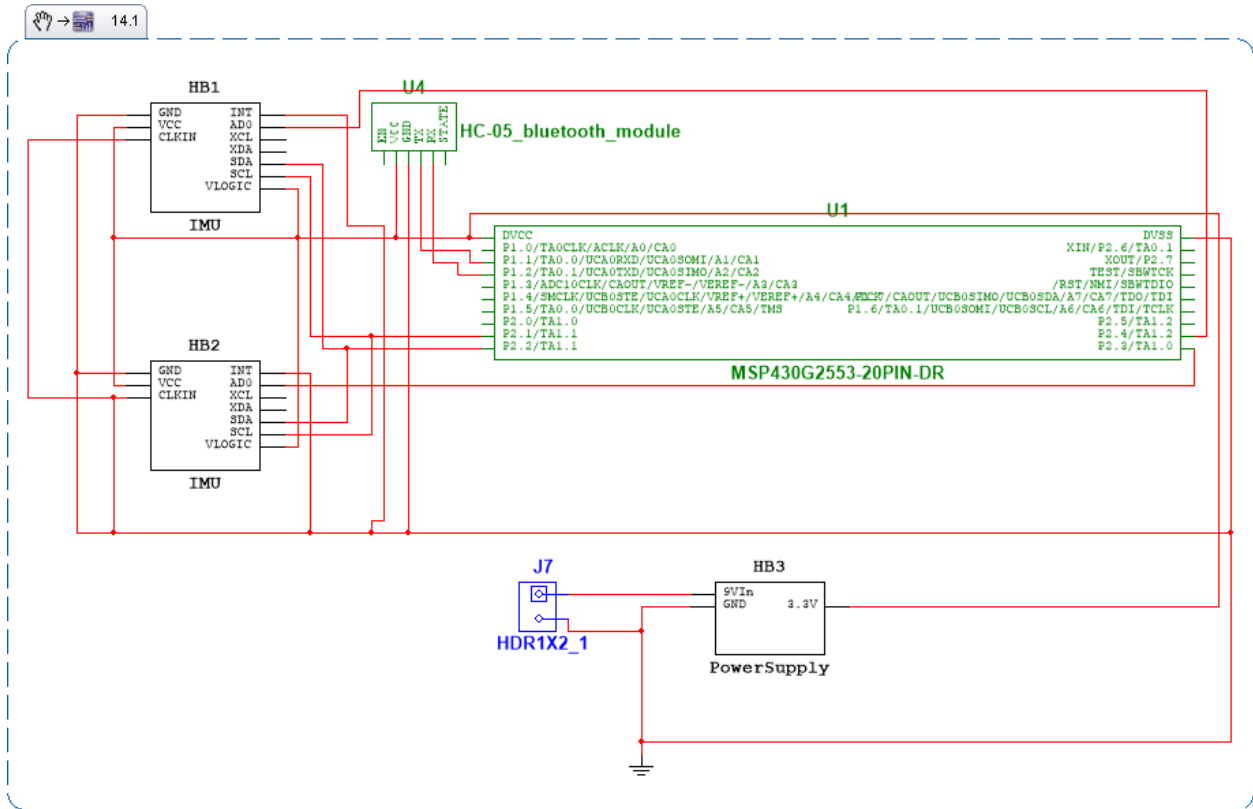

Figure 6: Headset subsystem schematic

The connections between the MSP430 and HC-05 Rx and Tx pins are set by UART requirements and the connections between the IMUs and the MSP430 are set by I2C conventions, however the ADO pins on both IMU blocks can be connected to any available output pins on the MSP430. They must not be connected as shown in Figure 5 so long as one is set low and the other set high for addressing purposes. In the modular approach to the automated ring light, the IMU hierarchical block is replaced by a prefabricated MPU-6050 module [11] connected to the microcontroller in the same way that an IMU hierarchical block is. The use of the module is a helpful design decision while debugging hardware and software issues in this project as it isolates one problem from the other. By using the module, one gets a much higher guarantee of functioning hardware and can develop software with the knowledge that any bugs must be software based. Following the development of software using the modular IMU, the system can be switched back to the custom PCB approach. At this point, issues can be isolated as hardware issues as the software has already been debugged with a working IMU module.

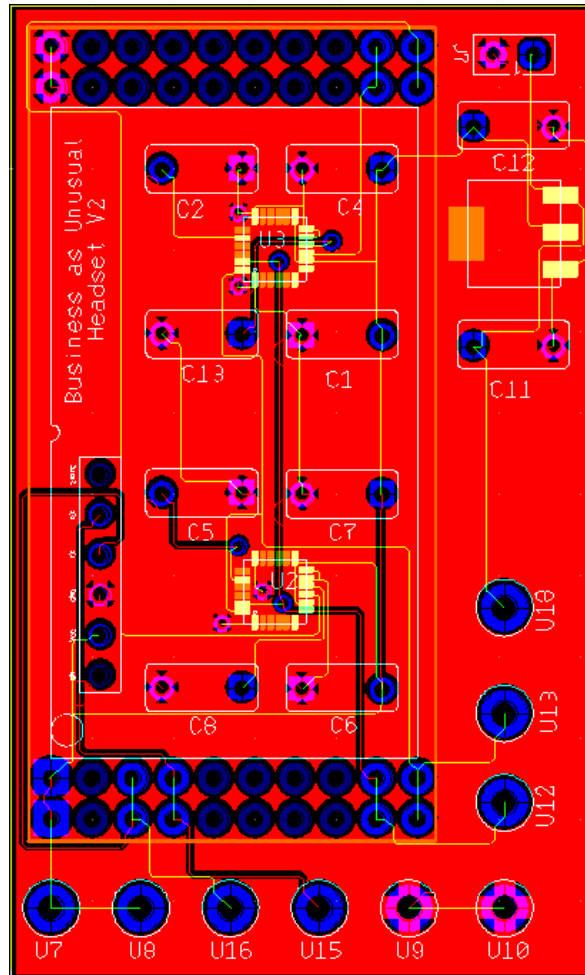

Figure 7: Board layout for the headset subsystem

The final board layout used for the headset subsystem is shown in Figure 7. There was a previous board edition where the Rx and Tx lines between the microcontroller and the bluetooth module were erroneously switched, but that was addressed in this final board sendout. The design of the IMU capacitor layout was determined by specifications provided in the data sheet. The voltage regulator bypass capacitors were also oriented according to the provided specification. Figure 7 contains test points which were not included in the earlier schematic in Figure 6. Generally, the testpoint included in this board are for ground, voltage regulator input, voltage regulator output, and digital logic outputs for I2C so connections between components could be verified during testing.

The layout for this subsystem was designed to be compact so that it would not extend far beyond the footprint of the MSP430 launchpad and thus could be fit easily on to a head piece for final testing at the conclusion of the project. The locations of the test points were also carefully selected so that mock power could be supplied from a VirtualBench function generator instead of constantly testing with and depleting the 9V battery.

One problem with the layout in Figure 7 is that I2C is very difficult to get right with two custom implementations of the IMU on the same bus. The best way to mitigate the risk of unsuccessful connection between the IMU array and the microcontroller is to keep on hand the modular IMU solution used earlier in the software development phase of the project.

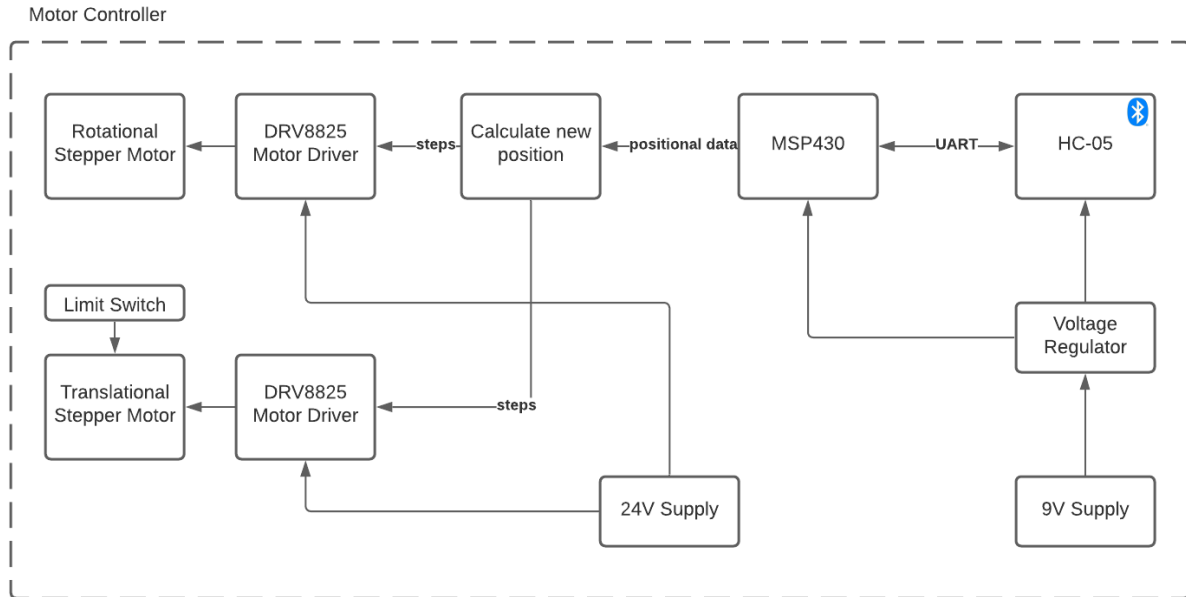

Figure 8: Block diagram of the motor controller subsystem

Figure 8 displays the block diagram of the motor controller subsystem. The MSP430 and the HC-05 bluetooth module are powered in the same way they are powered in the previous subsystem with a 9V supply and a voltage regulator to deliver a reliable 3.3V to these components. New in this subsystem are the DRV8825 motor driver chips [15], the NEMA17 [15] stepper motors, the limit switch on the translational stepper motor [15], and the 24V supply.

This subsystem uses a modular approach to the DRV8825 as implemented by Pololu [15]. This was a design choice in light of completing the project in a virtual environment and the need for reduced hardware debugging. The limit switch is included on either end of the physical apparatus shown in Figure 12. These are in place to protect against overstepping off the rails for the translational stepper motor.

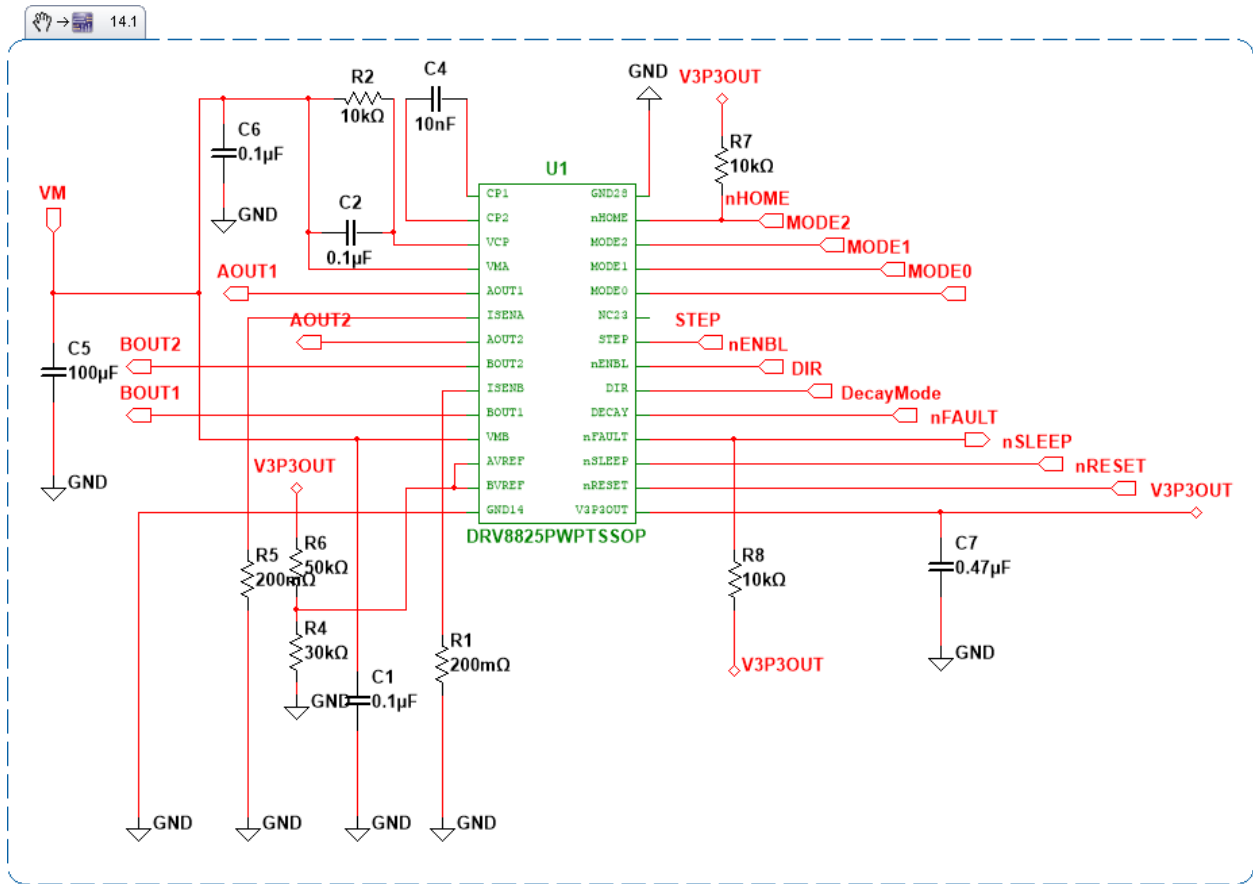

Figure 9: DRV8825 Motor driver chip implementation

Figure 8 shows the supporting circuitry for the DRV8825 driver chip as outlined in the specification for this component. The original plan in this project was to use this design on the motor control PCB, however the design specification also had specific component layout requirements that were difficult to implement properly in the amount of board space intended for this subsystem. As such, the use of a module was preferred for this component and is what was ultimately used in the project. The Pololu DRV8825 Stepper Motor Driver Carrier follows a very similar design pattern and can be inspected via the referenced data sheet.

There are more connections present in the schematic in Figure 9 than were ultimately used in the modular approach to this component. For example, this driver chip uses an inverted enable input with a pull down resistor and is thus active low. Since would always be needed in this project, the enable was left as on by default and unconnected to the microcontroller. This was an oversight in the first generation of this board and was corrected later as it is helpful to have access to the enable during debugging even if in the final project the motors would always be active anyway.

This driver chip also supports microstepping which was also only added in the second generation of the board during this project. Not including microstepping makes for a simpler hardware implementation and easier software development, however microstepping can be necessary in other versions of the project. For example, should the weight of the ring light be significantly greater than the two ounce ring light used in this project, microstepping would be

needed to slowly overcome the inertia of the light and begin translational motion and then be used to slow it down again at the end of motion. The stepper motor used for the rotational motion of the ring light in this project did not have microstepping enabled even in the second iteration as the rotational motion was not expected to be as dramatic as translational motion.

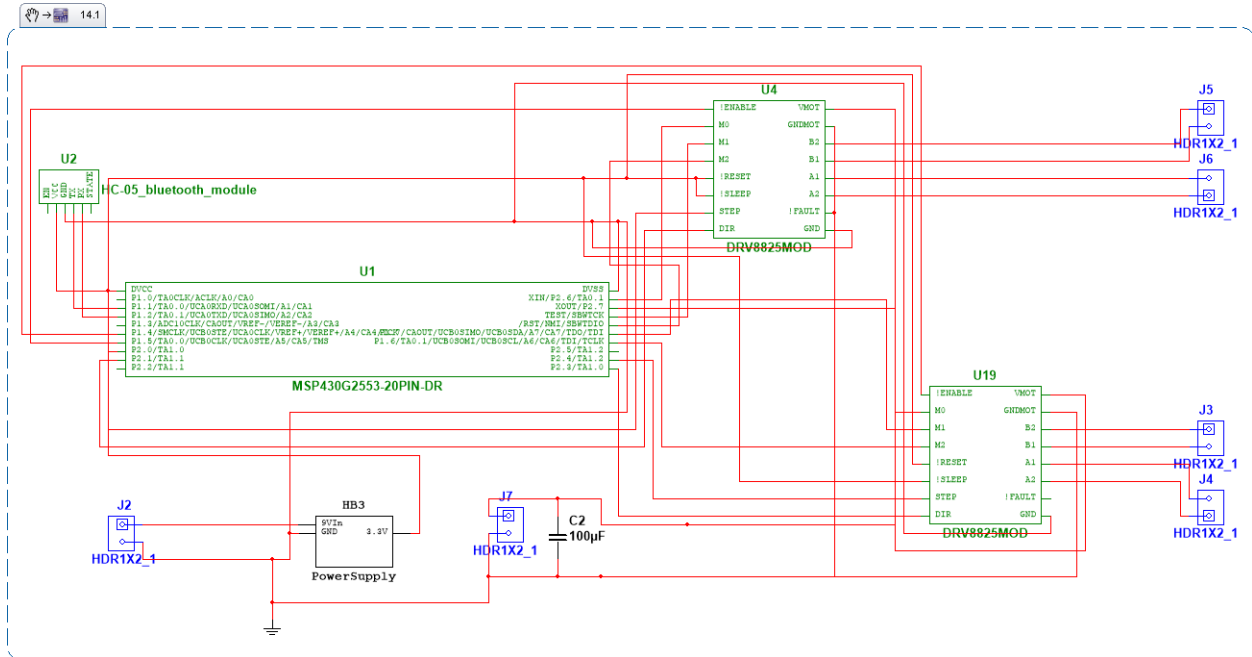

Figure 10: Motor controller subsystem schematic

The final schematic for the motor controller subsystem is shown in Figure 10. This schematic ultimately used the modular approach to the DRV8825 stepper motor driver. The J2, J5, J6, and J7 components are standard male pinouts [15] to allow jumper connections to the batteries and NEMA17 stepper motors. Capacitor C2 is needed at the input of the 24 V power supply to provide bypass for the stepper motor drivers. Originally this design also included another battery and voltage regulator component to provide 5V to the bluetooth module, however this was removed as 3.3V was still adequate and in the range specified in the data sheet. This made the overall design more straightforward as this component could use the same power supply as the microcontroller.

The limit switches were also not included in the first iteration of the project but were added on to the final version as an added reliability feature. For proof of concept implementations of the project they are not entirely necessary, but they were added to the design in this case on expert recommendation.

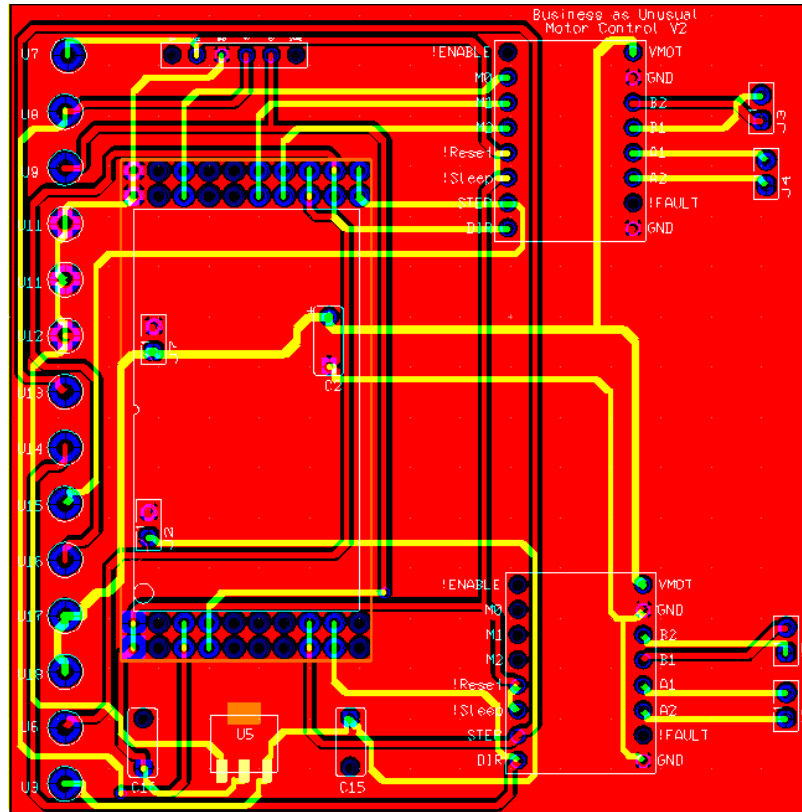

Figure 11: Motor Control PCB

Figure 11 shows the final PCB for the motor control subsystem. In this version, driver modules are used in place of the driver chip circuitry shown in Figure 10. This design decision was made because the layout of supporting circuitry for the DRV8825 as required by the component specification could not be achieved in the project timeframe. In this version of the PCB, microstepping was enabled for the first driver chip, but the enable inputs are still relying on the internal pull down resistors to achieve the active low and keep the driver module enabled. For this subsystem, the bluetooth module receives the IMU data and provides it to the microcontroller where the microcontroller determines the steps and direction needed on each of the motors to match the received motion data. The microcontroller then generates square waveforms of the calculated frequencies to drive the motors according to the motion decision.

The frame apparatus, as seen below in Figure 11: Frame Apparatus, consists of a stand, a track with a pulley system, and two stepper motors. The frame is designed to be wide enough to both support the track, but to also allow for a computer to be in between the legs. It has a mounted motor that moves the pulley system which moves a wheeled platform. The second motor is mounted vertically to the wheeled platform, which allows for the rotational movement of the ring light. It also has two switches at either end of the track, which allows for the device to know when it has reached the end of the track in order to prevent damage to the motors.



Figure 12: Frame Apparatus

Project Time Line

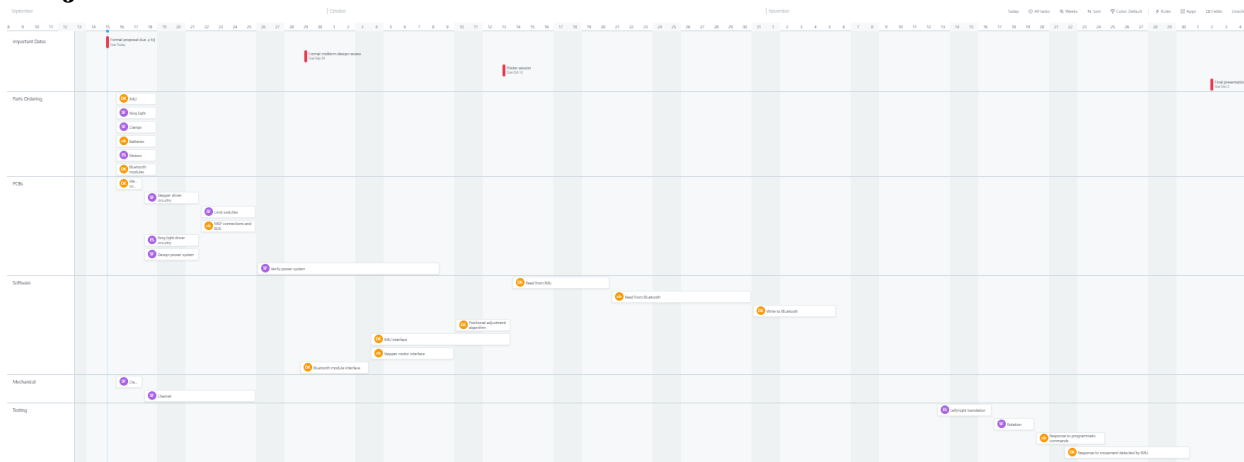

Figure 13: Gantt Chart from project proposal

The general assessment for the Gantt chart, shown in Figure 13, from the project proposal is that it was overly optimistic. It did not allow enough time for mistakes such as missed board sendouts, potential lab closures, and major redesigns that were needed for some subsystems. Another area of weakness was the tasks that were parallelized, such as the headset software development and the motor control software development did not account for situations where an “all hands on deck” approach was needed to solve the problem. For example, near the conclusion of the project there were unforeseen issues with the driver chips where they were burning out due to current limitations. This original Gantt chart did not include time for the team to swarm on one issue. In the end, the team did take an “all hands on deck” approach to getting the system demo

ready, but it did mean some reach goals were left off as future work as team members had to be pulled from other areas.

Another area the original plan had to be adjusted in was that testing progressed at very uneven rates for the headset subsystem and the motor control subsystem. This originally parallized task slid into more of a serialized state which meant that time was not left for producing an even higher fidelity prototype at the end of the semester as was originally planned as per the grading criteria set out in the project proposal.

Due to the compressed nature of the project timeline, there were a few significant events that severely affected the tasking for the project as was initially planned in the project proposal. As selection for components such as driver chips and IMUs took longer than expected, it suddenly became clear that the overall system schematic would need to be fleshed out quickly in time for design reviews.

To finalize the schematics as fast as possible, the team member responsible for the original block diagrams was delegated to realize the design in Multisim. Then that decision snowballed into that team member being responsible for more hardware design decisions as they were more familiar with the system so far. That decision led to a semester of hardware work for a team member, Daniel, who initially was tasked with primarily software work. Sophia, who would have been best tasked with leading the hardware work had been kept occupied by mechanical work. She later took the lead on the finalization of the software for the demo. Ethan’s primary responsibility shifted to testing by the end, however this change was noted and approved at midterm design reviews. Generally, there was poor tasking in major areas for the duration of the project and much of the software work had to be accomplished on a compressed timeline. The primary and secondary responsibilities for The recommendation of this team to future teams looking to undertake a similar project is to adopt a more authoritarian approach to task management instead of relying on timetables enforced by each individual unto themselves.

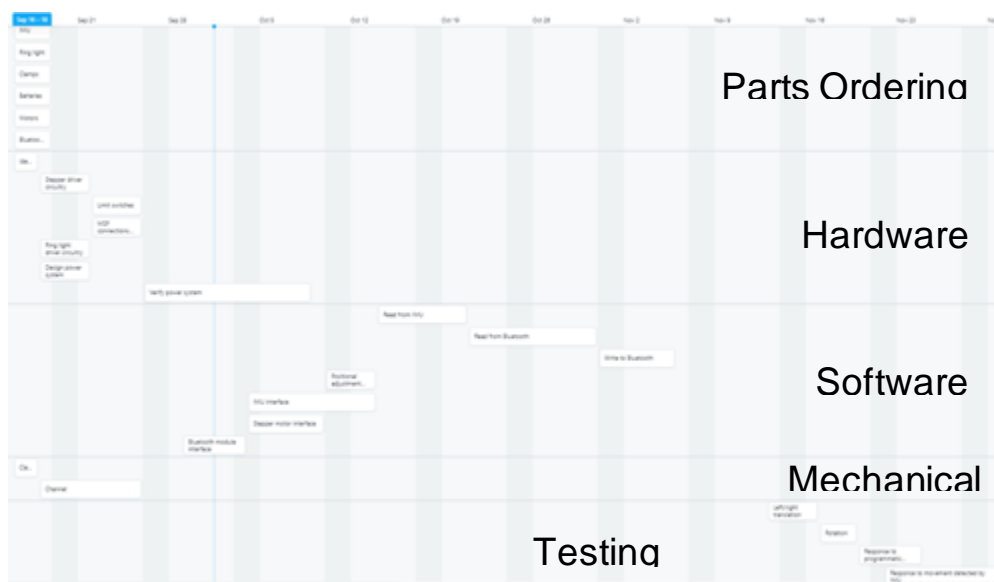

Figure 14: Final Gantt chart

After working through the issues encountered and embracing flexibility in the name of completing a minimum viable product, the final Gantt chart for this project was very different from the original proposal. Figure 14 presents this modified Gantt chart as is representative of the project at the end of the semester.

Test Plan

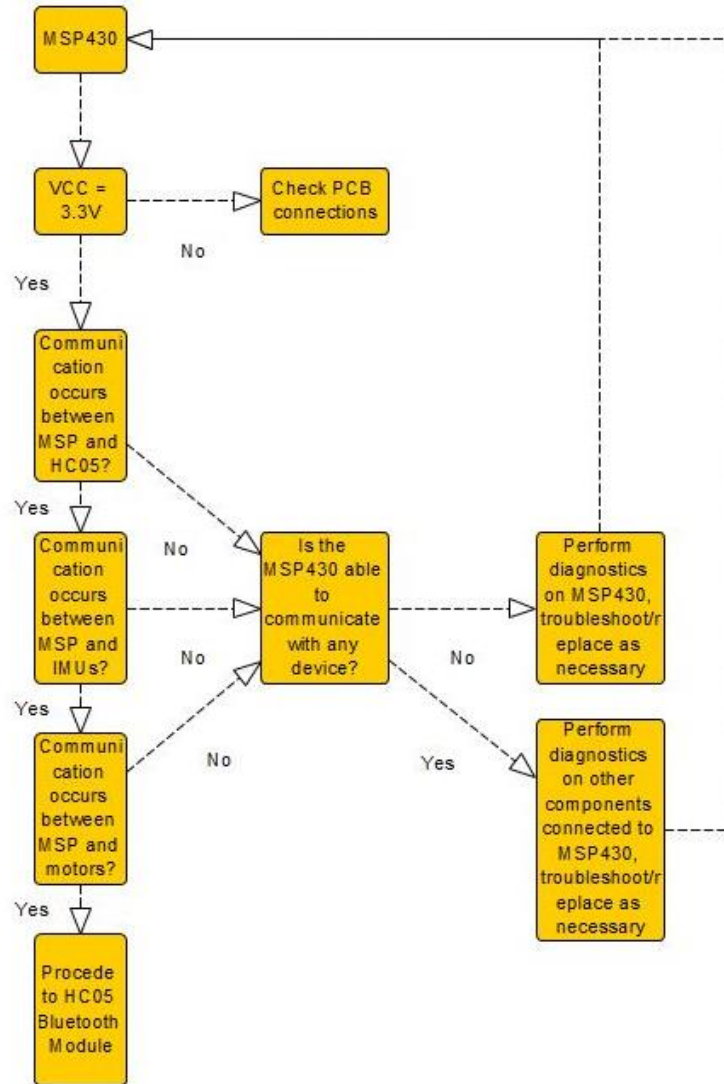

Figure 15: MSP430 Test Plan

Figure 15 shows the MSP430 test plan that was drafted during the Midterm Design Review. As our team progressed through the rest of the semester, we altered the above test plan by having the “Communication occurs…” blocks be more freeform throughout the prototyping and testing portions of the project. Our team still did start the construction phase of the project with the MSP430, but we did redesign all of the test plans to work in a concurrent manner rather than a sequential manner. The primary testing procedure of verifying communication between the MSP430 and the other modules of the system still did occur throughout the testing process. Through iterative testing and designing, our team was able to send data from the MSP to the

Bluetooth module, receive data from the IMU to the MSP, and communicate with the stepper motors.

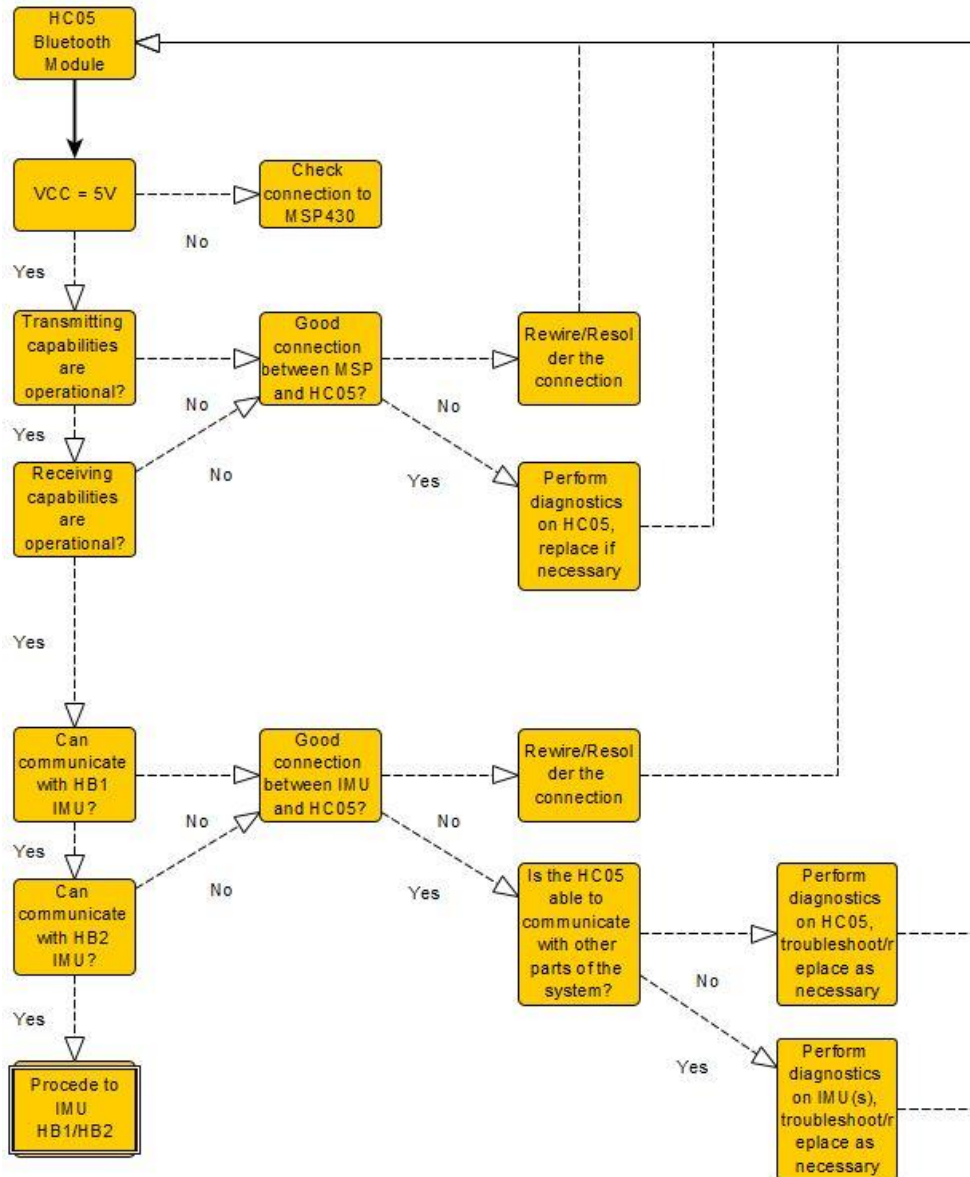

Figure 16: HC05 Bluetooth Test Plan

Figure 16 shows the HC05 Bluetooth module test plan that was drafted during the Midterm Design Review. This test plan was still followed during the prototyping and testing portions of our project. Transmitting and receiving capabilities of the Bluetooth module were designed and tested primarily through communication with a Bluetooth terminal present within a team member’s laptop. This baseline communication served as a reference point for this module for the rest of the semester. Through an indirect connection, Bluetooth data was received from the MSP430. Specifically, data from the Bluetooth module was sent to the Bluetooth terminal in the laptop. The laptop communicated this data to the MSP430 through a program, which then sent said data back to the Bluetooth module. However, a direct communication link between the Bluetooth module

and the MSP430 did not occur at the end of the project. Such an indirect communication method also allowed the IMU module to communicate with the Bluetooth module.

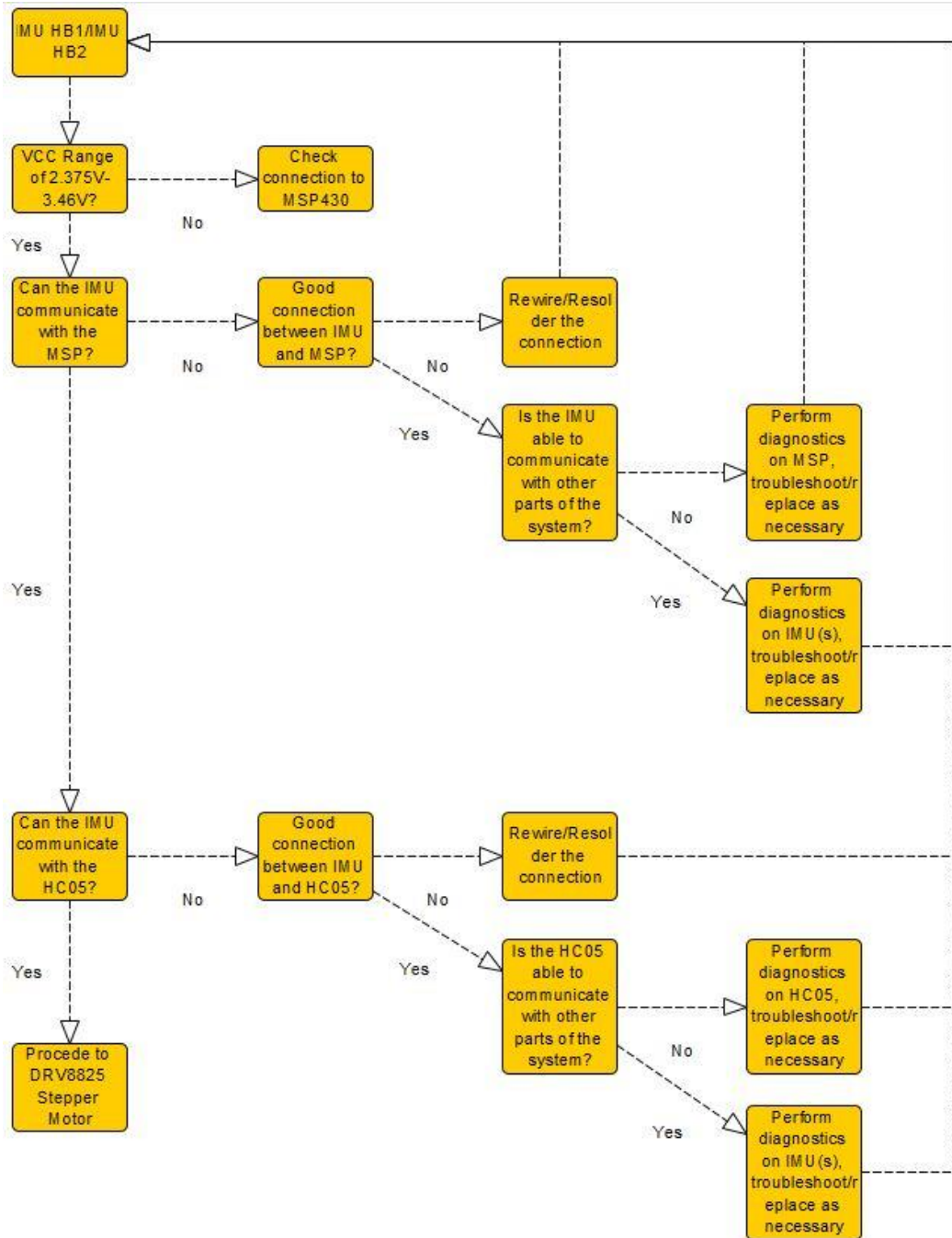

Figure 17: IMU Test Plan

Figure 17 shows the IMU test plan that was drafted during the Midterm Design Review. The overall desired results from the test plan was still present within the prototyping and testing portion of our project. However, this test plan was altered to have the communication blocks occur in a concurrent manner rather than a sequential manner. IMU communication occurred in a direct fashion to the MSP430. Data was sent from the IMU to the MSP430, and vice versa for receiving

capabilities. As stated in the Bluetooth Test Plan section, communication between the IMU and the Bluetooth modules occurred in an indirect fashion. Data was sent from the IMU to the MSP430, which was subsequently communicated to the Bluetooth module from the MSP430. A reverse form of this communication was not able to be created.

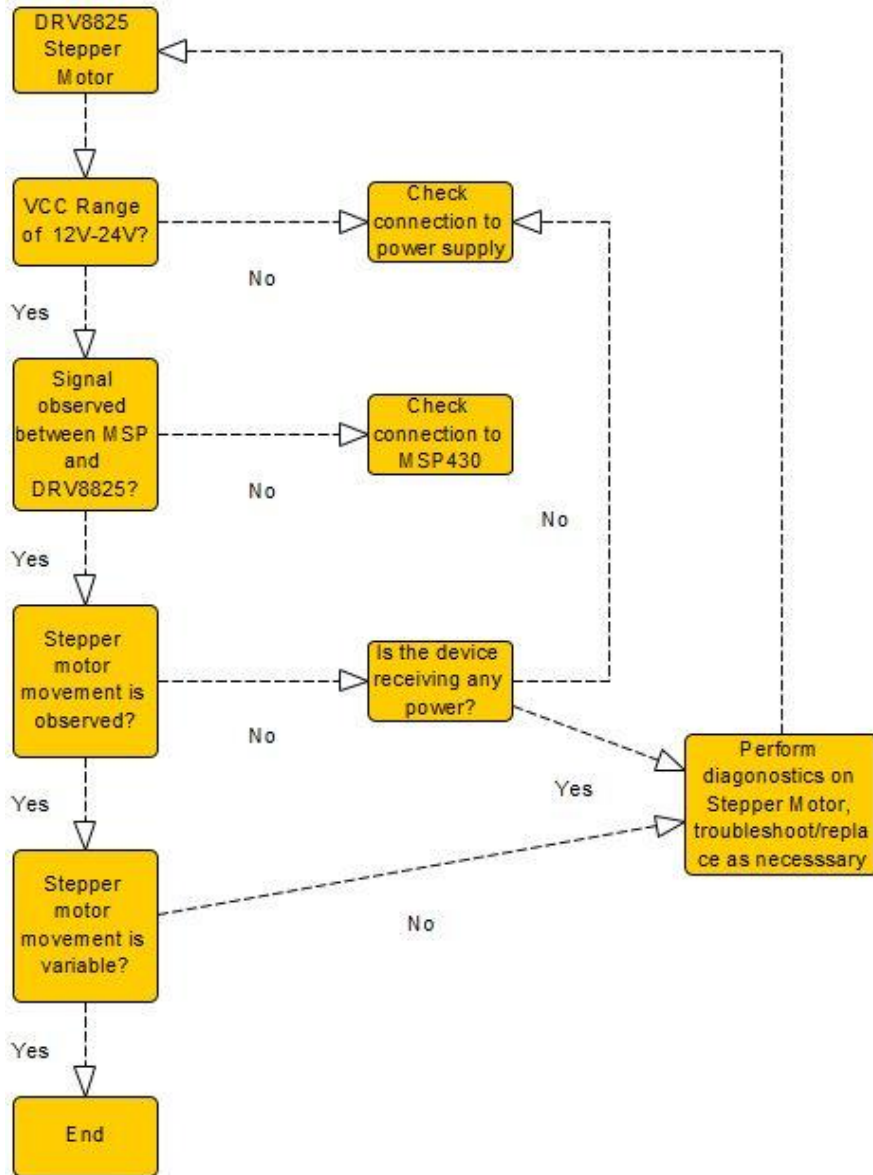

Figure 18: DRV8825 Stepper Motor Test Plan

Figure 18 shows the DRV8825 stepper motor test plan that was drafted during the Midterm Design Review. This test plan was not altered throughout the design process of the project. The initial testing steps shown above are self-explanatory: our team ensured that proper functionality occurred from the stepper motor within the specified voltage range. Afterwards, we sent a test program to the MSP430 that would utilize the stepper motor in a basic fashion. Once both of these steps were completed, our focus shifted to implementing the more complex functionalities we required for our project. Through some iterative testing, our team was able to cause basic rotational

movement in both clockwise and counterclockwise directions from the stepper motors. The portion of stepper motor testing that required extensive prototyping and testing was the variable movement our team desired from the stepper motor. After some basic hardcoding of small test programs, our team was able to implement some limited variable movement from the motors.

Final Results

First, we verified the power throughout the device was being applied as intended. This included measuring the power given to the stepper modules, motor, and other embedded devices in the project. These measurements confirmed each module was receiving the necessary power to successfully operate. Shown in Figure 19 is an example of these measurements. The measurement shown in Figure 19 is the resulting output voltage from the PCB's voltage regulator.

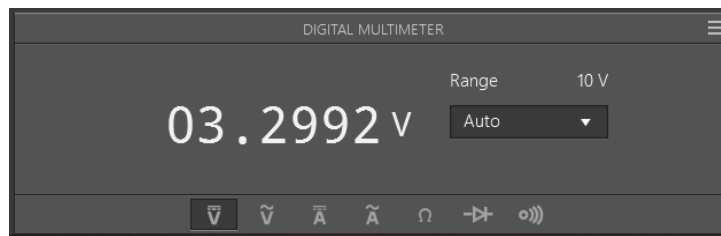

Figure 19: Power Verification Measurement

In regards to the bluetooth connectivity we first verified that each separate module was able to function. To do this we used an android smartphone and the Serial Bluetooth Terminal app to connect to each module. Using the terminal we were able to transmit a command to the bluetooth module that turned off and on the onboard green LED. Shown in Figure 20 is the terminal output of the command successfully being sent and executed.

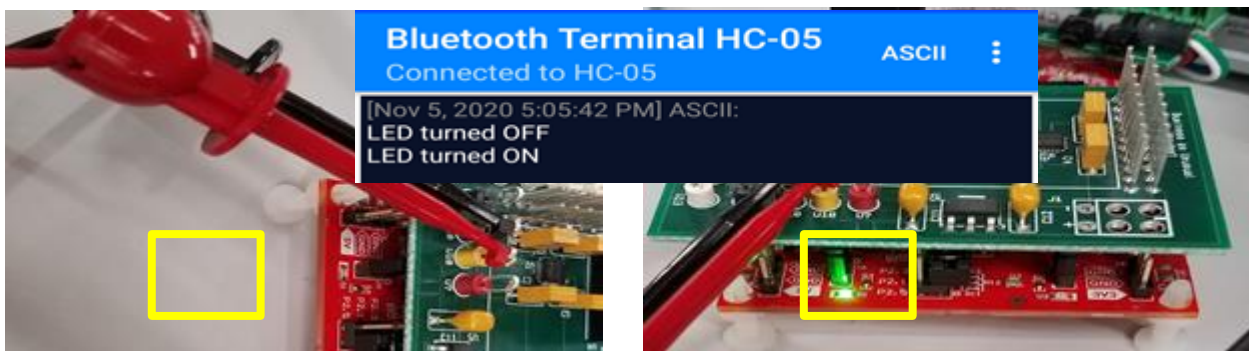

Figure 20: Bluetooth Module Verification

Following the verification of basic functionality for the bluetooth modules we then verified that the headset bluetooth module, that was connected to the Inertial Measurement Unit (IMU) was able to function in tandem with the bluetooth module itself. Using a desktop Bluetooth terminal,

we confirmed that we were able to send IMU data via Bluetooth, as seen below in Figure 21: IMU Data Over Bluetooth.



Figure 21: IMU Data Over Bluetooth

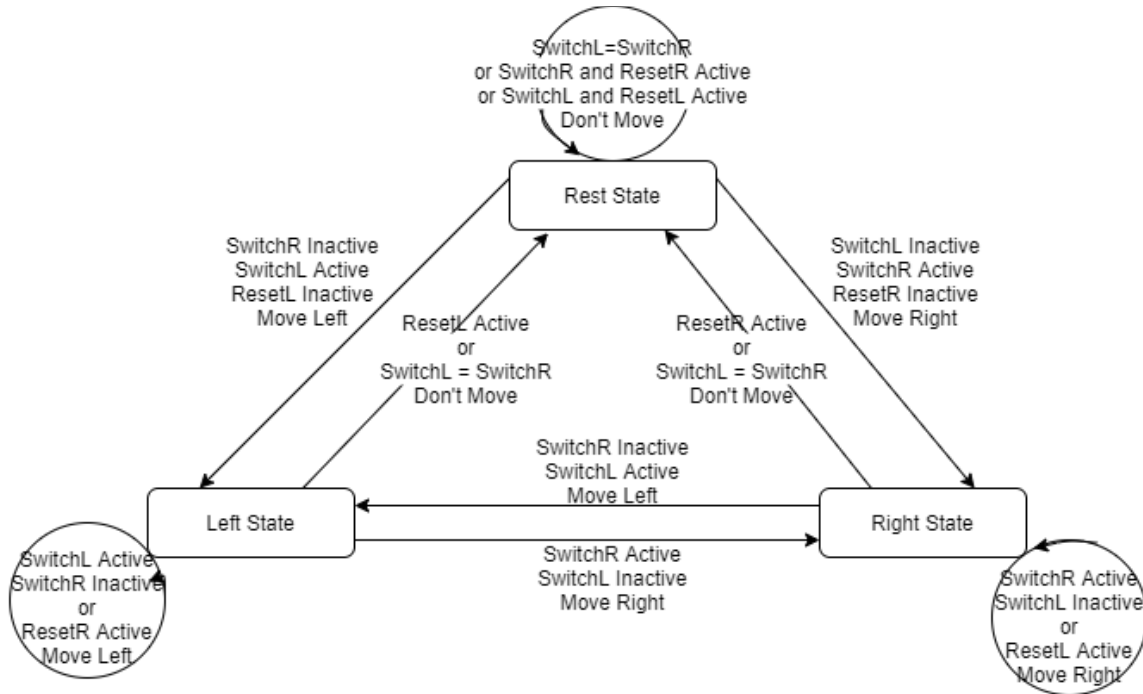

Figure 22: Finite State Machine

In the end, the ring light was able to be moved laterally left and right by utilizing switches in real time. It was also able to stop the ring light from colliding with the edges of the track by utilizing switches on either end. This was done by following the finite state machine shown above in Figure 22: Finite State Machine. It took into account which direction the user directed the ring

light with SwitchL and SwitchR, and moved the ring light in the indicated direction by setting the direction of the lateral movement motor along with toggling the bit required to generate the square wave necessary for driving the motor. It also knows to either stop or reverse the ring light if it collides with the switches at the edge of the track, ResetR and ResetL.

We defined an acceptable goal for the Automated Ring Light is for it to be able to move well in real time with given commands. This would qualify as a B grade result of the project. Since we were able to achieve movement in response to real time commands, it would meet the qualifications. It also had the added bonus of having functioning end switches. However, it lacks the rotational movement we also required. Thus, it should be a lower B grade.

Costs

The total cost of development of this project is calculated as \$379.65. A detailed report of all the costs incurred during the project can be found in Table 1 in the Appendix. This cost is not reflective, however, of the cost a party should expect should they choose to complete a similar project. The frame apparatus that held the ring light and its rail and the motors were salvaged from a previous project and thus are not represented in the costs listed in the Appendix.

While there are two MSP430 launchpads listed in the costs in Table 1, development of this project was aided by using an additional two launchpads that were not purchased. These two additional launchpads allowed for more parallelization and distribution of tasks. This additional equipment was very helpful in the development of this project and would be a helpful investment for future groups interested in completing this project. Similarly, the cost of these additional MSP430 launchpads are not included in the summary of costs in Table 1 in the Appendix.

Should the automated ring light be produced at scale, the per unit cost of 10,000 units is estimated to be \$62.40. A thorough breakdown of the costs associated with this total can be found in Table 2 in the Appendix. This estimation is variable for a number of reasons. Firstly, the PCB production cost can only be roughly estimated at this scale without receiving a direct quote for a final design. Secondly, this costs includes a high cost for the two motors used in the project. The chosen manufacturer did not have a bulk order price available publicly on with the chosen vendor, however it is very likely that the total cost would be reduced by a special bulk rate with the manufacturer of the motors. Thirdly, the bluetooth module which was used in the project as a proof of concept would not be used in a mass produced final version of this project. The estimated cost uses the cost of the chip used in the module but does not factor in the cost of the supporting circuitry for the bluetooth chip. The cost of the product is again made lower by the assumption that the end user provides their own ring light. Alternatively, this product could be marketed directly to ring light manufacturers and it could be sold as an accessory to their products.

Future Work

The first recommendation to help improve the automated ring light is to ensure the motors are able to respond to the IMU data. This would require calibrating the results to be able to determine not just the acceleration of the motion, but also remembering the previous position in order to predict the next position. Next, the optimal ring light positioning needs to be calculated.

It also requires accounting for any potential errors along with accounting for the natural movement of the head even when not moving.

The second recommendation would be to consider utilizing two LNAs instead of an IMU to determine the positioning of the head. This would allow for less calculations and errors when calculating the next position of the ring light. The calculations could be done by utilizing basic trigonometry to determine the angle between the user's head, and the two LNAs, and the ring light stand, which then allows for a simple calculation to find the optimal position and angle of the ring light.

To better improve the movement of the ring light, speed variability and microstepping should be added. First off, the speed variability would allow for the ring light to move at different speeds depending on the distance it needs to travel, thus reducing lag with longer movements, while also minimizing possible inertial issues for smaller movements. Secondly, microstepping should be utilized to help better handle weight of the device, especially at slower speeds. Using microsteps to better start and stop the device would also help address possible inertial issues when making the faster, loner movements. It would also aid with the rotation of the ring light, due to the mass of the ring light creating problems for starting and stopping rotation at lower speeds.

The final recommendation is in regards to marketability and appearance. It is to make the headset portion of the project smaller and more finished appearing, possibly by adding a casing. Additionally, adding a more flexible method to mount the module to either the hat or headset of the individual. Along with making the modules more presentable, the PCBs should be made smaller and more compact by utilizing the bluetooth and IMU chips instead of modules. This would help make the device more sleek and convenient. Finally, a longer track should be utilized in order to allow for better lighting with cases that have more head rotation.

References

- [1] J. A. Morente, A. Salinas, S. Toledo-Redondo, J. Fornieles-Callejon, A. Mendez, and J. Porti, "A New Experiment-Based Way to Introduce Fourier Transform and Time Domain Frequency Domain Duality," *IEEE Trans. Educ.*, vol. 56, no. 4, pp. 400–406, Nov. 2013.
- [2] "MSP430G2553 | MSP430G2x/i2x | MSP430 ultra-low-power MCUs | Description & parametrics." [Online]. Available: <http://www.ti.com/product/MSP430G2553>. [Accessed: 06-Dec-2016].
- [3] Kelly Vivian, "New IEEE 802.11Ac™ Specification Driven By Evolving Market Need For Higher, Multi-User Throughput In Wireless Lans," IEEE, Jan. 2014.
- [4] Bluetooth Core Specification Version 5.2 Feature Overview, Version 1.0, Jan. 2020.
- [5] UNIROSS, "UNIROSS Study on the Environmental Impact of Batteries," yumpu.com, 2007. [Online]. Available: <https://www.yumpu.com/en/document/view/16577293/uniross-study-on-the-environmental-impact-of-battery-logic>. [Accessed: 09-Dec-2020].
- [6] Lim, S., Kang, D., Ogunseitan, O. and Schoenung, J., "Potential Environmental Impacts Of Light-Emitting Diodes (Leds): Metallic Resources, Toxicity, And Hazardous Waste Classification", 2010. [online] Available: <https://pubs.acs.org/doi/10.1021/es101052q> [Accessed 14 September 2020].
- [7] Mahajan, Ritu. (2007), The Naked Truth: Appearance Discrimination, Employment, and the Law. *Asian American Law Journal*, 14(1), 165-204. HeinOnline.
- [8] Bartlett, K. T. (1994). Only Girls Wear Barrettes: Dress and Appearance Standards, Community Norms, and Workplace Equality. *Michigan Law Review*, 92(8), 2541–5282.
- [9] V. V. Vo, M. R. Leshner, S. A. Moya, and M. K. Huang, "Remote control track light fixture," 2012.
- [10] 모간 콜리야 베나블, 베르나르드 제임스 커, and 위라판 위라이랏, "Target positioning with gaze tracking," 2014.
- [11] InvenSense, "MPU-6000 and MPU-6050 Product Specification Revision 3.4," datasheet, Sept. 2013.
- [12] Texas Instruments, "MSP-EXP430G2 LaunchPad™ Development Kit," SLAU318G datasheet, July 2010 [Revised March 2016].
- [13] ITead Studio, "HC-05 Bluetooth to Serial Port Module," datasheet, July 2010.
- [14] Texas Instruments, "Stepper Motor Control Using MSP430™ MCUs," SLAA785 datasheet, Sept. 2017
- [15] Pololu Robotics & Electronics, "Stepper Motor with 18cm Lead Screw: Bipolar, 200 Steps/Rev, 42×38mm, 2.8V, 1.7 A/Phase," 2689 datasheet, 2012.

Appendix

TABLE 1
Project Development Costs

Item	Cost	Date Ordered	Date Received
Bluetooth Module	12.00	7-Sep	10-Sep
MSP430 Launchpad	23.98	18-Sep	2-Oct
CPVC	16.59	20-Sep	20-Sep
CPVC Saw	10.98	20-Sep	20-Sep
Ring Light	28.42	2-Oct	2-Oct
CPVC Cement	7.12	2-Oct	2-Oct
Light Mount	5.54	10-Oct	10-Oct
CONN HDR 6POS 0.1 TIN	1.04	27-Oct	29-Oct
CONN HDR 10POS 0.1 GO	2.60	27-Oct	29-Oct
IC REG LINEAR 3.3V 1A SOT223	2.38	27-Oct	29-Oct
PC TEST POINT MULTIPURPOSE RED	1.20	27-Oct	29-Oct
PC TEST POINT MULTIPURPOSE WHITE	4.80	27-Oct	29-Oct
PC TEST POINT MULTIPURPOSE BLACK	2.00	27-Oct	29-Oct
PC TEST POINT MULTI PURP YELLOW	1.20	27-Oct	29-Oct
TERM BLOCK PLUG 2POS STR 3.81MM	16.73	27-Oct	29-Oct
JUMPER WIRE M/F 2.950" 1PC	3.95	27-Oct	29-Oct
JUMPER WIRE F/F 2.950" 1PC	3.95	27-Oct	29-Oct
CONN SOCKET 20POS 0.1 TIN PCB	11.60	27-Oct	29-Oct
CAP CER 10UF 25V X7R RADIAL	3.12	27-Oct	29-Oct
CAP CER 2200PF 50V 2% RADIAL	9.88	27-Oct	29-Oct
CAP CER 0.1UF 50V BX RADIAL	4.32	27-Oct	29-Oct
CAP CER 10000PF 100V 10% RADIAL	3.20	27-Oct	29-Oct
CAP ALUM 100UF 20% 25V RADIAL	0.38	27-Oct	29-Oct
CONN HDR 6POS 0.1 TIN PCB	1.04	9-Nov	12-Nov
IC REG LINEAR 3.3V 1A SOT223	2.38	9-Nov	12-Nov
PC TEST POINT MULTIPURPOSE RED	1.20	9-Nov	12-Nov
PC TEST POINT MULTIPURPOSE WHITE	4.80	9-Nov	12-Nov

PC TEST POINT MULTIPURPOSE BLACK	2.00	9-Nov	12-Nov
PC TEST POINT MULTI PURP YELLOW	1.60	9-Nov	12-Nov
CONN SOCKET 20POS 0.1 TIN PCB	11.60	9-Nov	12-Nov
CAP CER 10UF 25V X7R RADIAL	3.12	9-Nov	12-Nov
CAP CER 2200PF 50V 2% RADIAL	9.88	9-Nov	12-Nov
CAP CER 0.1UF 50V BX RADIAL	4.32	9-Nov	12-Nov
CAP CER 10000PF 100V 10% RADIAL	3.20	9-Nov	12-Nov
CAP ALUM 100UF 20% 25V RADIAL	0.38	9-Nov	12-Nov
IMU ACCEL/GYRO 3-AXIS I2C 24QFN	15.10	9-Nov	12-Nov
CONN HEADER VERT 2POS 2.54MM	0.91	9-Nov	12-Nov
CABLE ASSY JST PH 2PIN 4"	5.25	9-Nov	12-Nov
BATTERY CONNECT SNAP 9V 6" LEADS	1.94	9-Nov	12-Nov
JUMPER WIRE M/M 6" 20PCS	1.95	9-Nov	12-Nov
STUDENT DSCNT PCB	132.00	23-Oct	28-Oct
		Total	379.65

TABLE 2
Bulk Cost Estimations for 10,000 Units

Manufacturer Part Number	Manufacturer	Digi-Key Part Number	Quantity per unit	Description	Bulk unit cost (10,000 units)	Expense
LMS8117AMP-3.3/NOPB	Texas Instruments	LMS8117AMP-3.3/NOPBCT-ND	2	IC REG LINEAR 3.3V 1A SOT223	0.44764	8952.8
5010	Keystone Electronics	36-5010-ND	3	PC TEST POINT MULTIPURPOSE RED	0.2523	7569
5012	Keystone Electronics	36-5012-ND	12	PC TEST POINT MULTIPURPOSE WHITE	0.2523	30276
5011	Keystone Electronics	36-5011-ND	5	PC TEST POINT MULTIPURPOSE BLACK	0.2523	12615
5014	Keystone Electronics	36-5014-ND	4	PC TEST POINT MULTI PURP YELLOW	0.2523	10092
C322C106K3R5TA	KEMET	399-13968-ND	4	CAP CER 10UF 25V X7R RADIAL	0.23114	9245.6
CCR05CG222GR	KEMET	1001-2278-ND	2	CAP CER 2200PF 50V 2% RADIAL	2.03363	40672.6

CK05BX104KT/R	KEMET	1001-2005-1-ND	4	CAP CER 0.1UF 50V BX RADIAL	0.33537	13414.8
M39014/01-1535	KEMET	1001-2183-ND	2	CAP CER 10000PF 100V 10% RADIAL	0.56994	11398.8
ESK107M025AC3AA	KEMET	399-6102-ND	2	CAP ALUM 100UF 20% 25V RADIAL	0.0338	676
MPU-6050	TDK InvenSense	1428-1007-1-ND	2	IMU ACCEL/GYRO 3-AXIS I2C 24QFN	3.3125	66250
MSP430G2553IPW20 R	Texas Instruments	296-28430-1-ND	2	IC MCU 16BIT 16KB FLASH 20TSSOP	0.99	19800
DRV8825PWPR	Texas Instruments	296-29503-1-ND	2	IC MTR DRVR BIPLR 8.2-45V 28SSOP	1.92	38400
324	Adafruit Industries LLC	1528-1062-ND	2	STEPPER MOTOR HYBRID BIPOLAR 12V	14	280000
BC417143B-GIQN-E4	Qualcomm	BC417143B-GIQN-E4CT-ND	2	IC RF TXRX+MCU BLUETOOTH 96TFBGA	2.66	53200
N/A	Sunshine Ltd	N/A	2	PCB Cost	1.07	21400
					Total	623962.60
					Per Unit	62.40